



WHITESTEIN
Technologies

Realizing Tangible Business Value from the Fusion of Autonomous and Autonomic Technologies

Dominic Greenwood
Head of Innovation

The Theme



Autonomous and Autonomic Computing

- ❑ Intrinsically linked concepts, with a long history
- ❑ Core aspects of contemporary distributed computing models
- ❑ Highly viable technologies for today's software engineering and business problems
- ❑ And they're pretty cool technology (IMHO)





Autonomous Technology

- ❑ Self-contained systems that can function independently of other components or systems by acquiring, processing and acting on environmental information

Autonomic Technology

- ❑ Computing systems capable of managing themselves using closed control loops without the need for any direct intervention

- ❑ Both draw on biological inspiration



Computational Mind

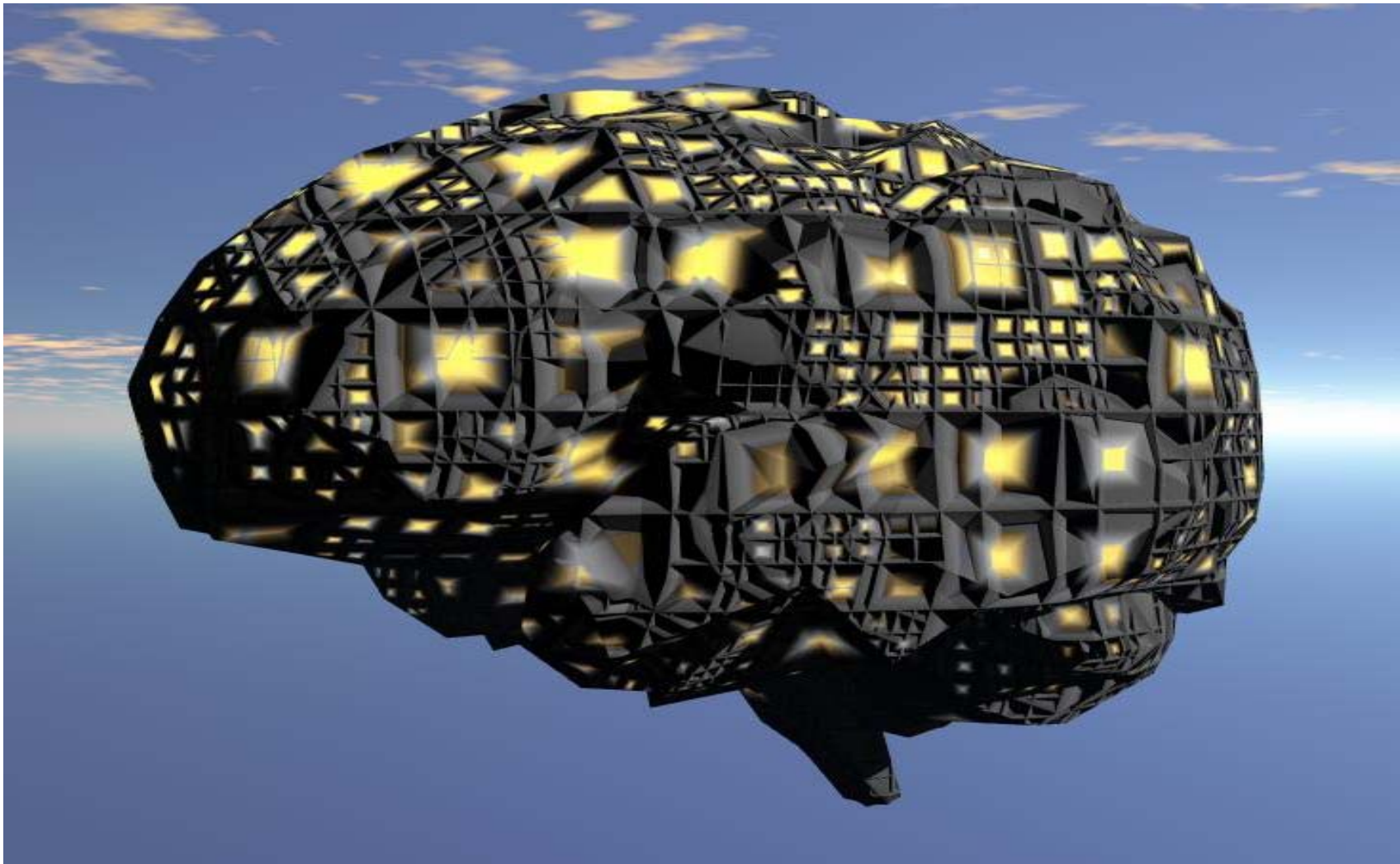

Photo: Credo Chronicler



TerraMax T2

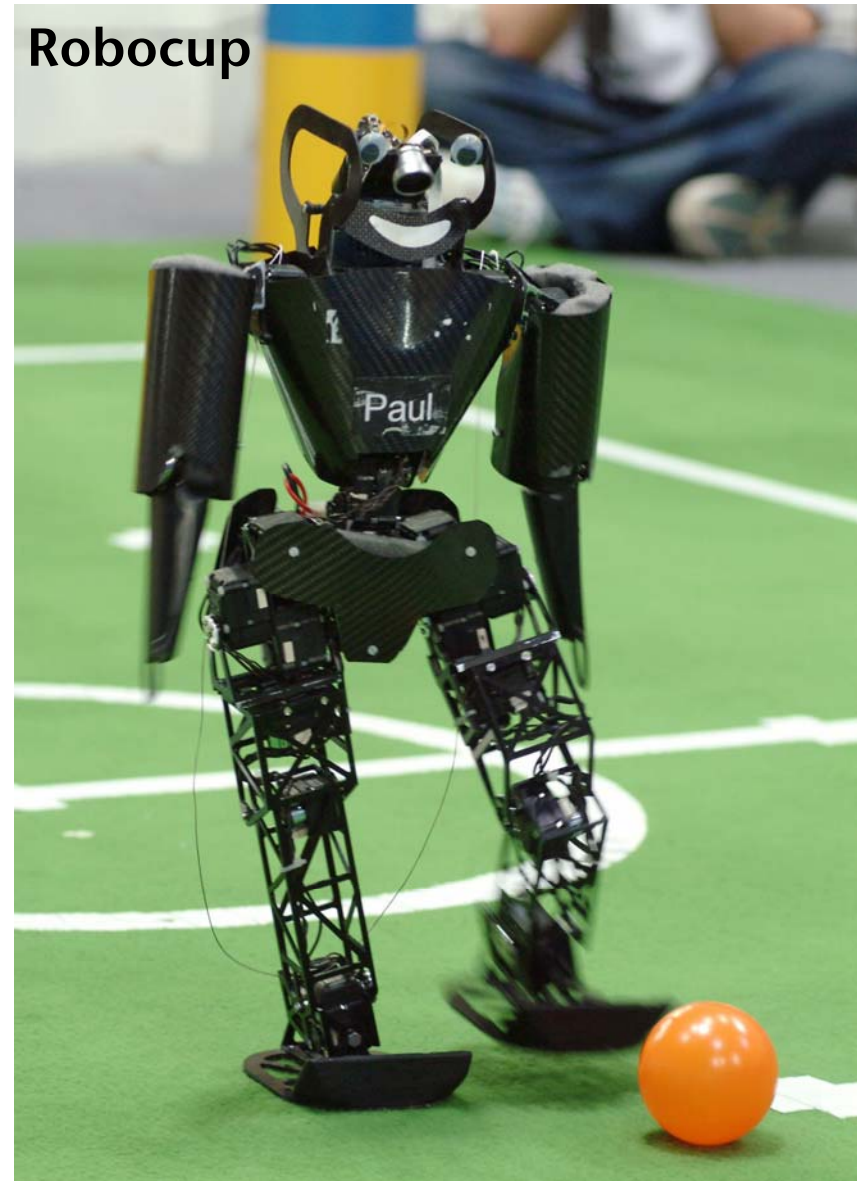
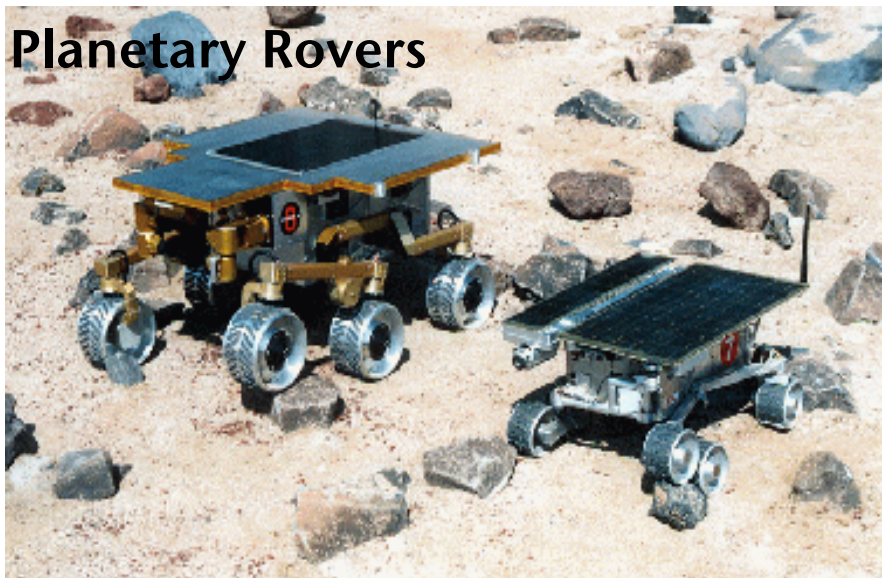
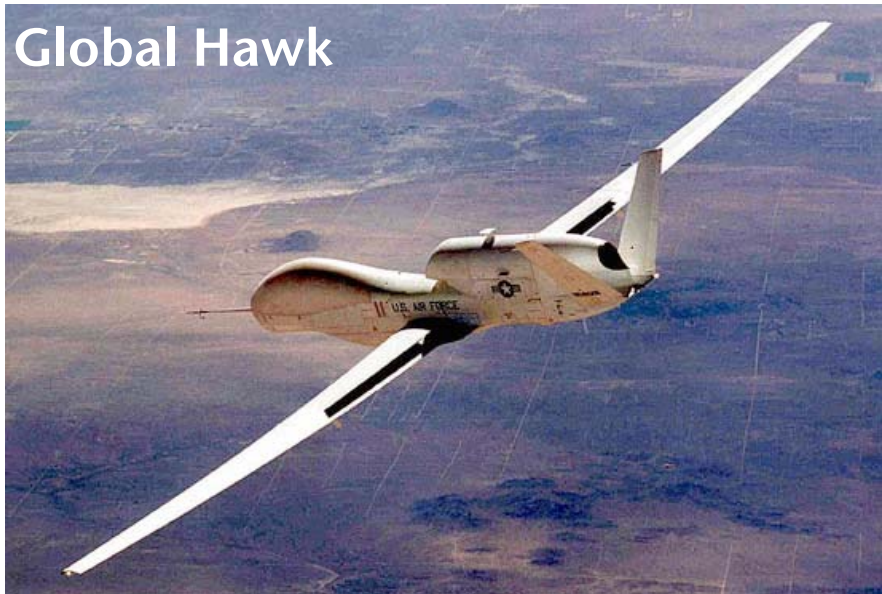

Photo: VisLab

Autonomous Technologies



Autonomous Technologies



Autonomous Controllers



The Common Factor

- ❑ A brain, or in other words...
 - ❑ A logic controller capable of sensing its environment and operating alone without persistent human intervention
- ⇒ Local control leads to global coordination

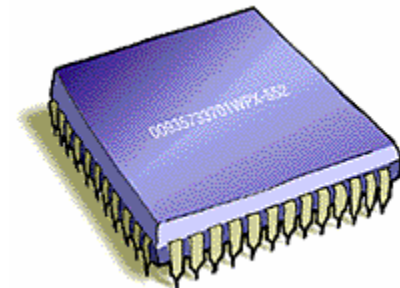

The brain

[An organ that] integrates sensory information from inside and outside the body in controlling autonomous function (such as heartbeat and respiration), both in coordinating and directing correlated motor responses and in the process of learning

- Merriam-Webster



**White Box\
Black Box**

Autonomous Controllers



Is this the same as a Software Agent?

- ❑ In short, yes ...
 - Non-dependent operation
 - Loosely-coupled interaction
 - Multiple forms of logic control
 - Ability to make a decision without intervention

- ❑ Except perhaps ...
 - Agents are often considered to be specialized *semantic communicators*
 - See FIPA ACL, SL/KIF, OWL, etc.

- ❑ In reality the two are effectively synonymous

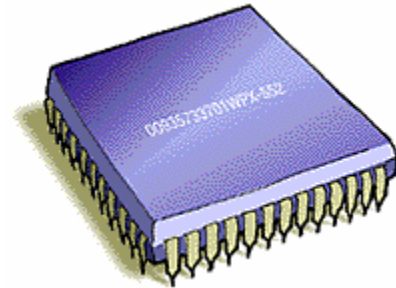



Computational Mind

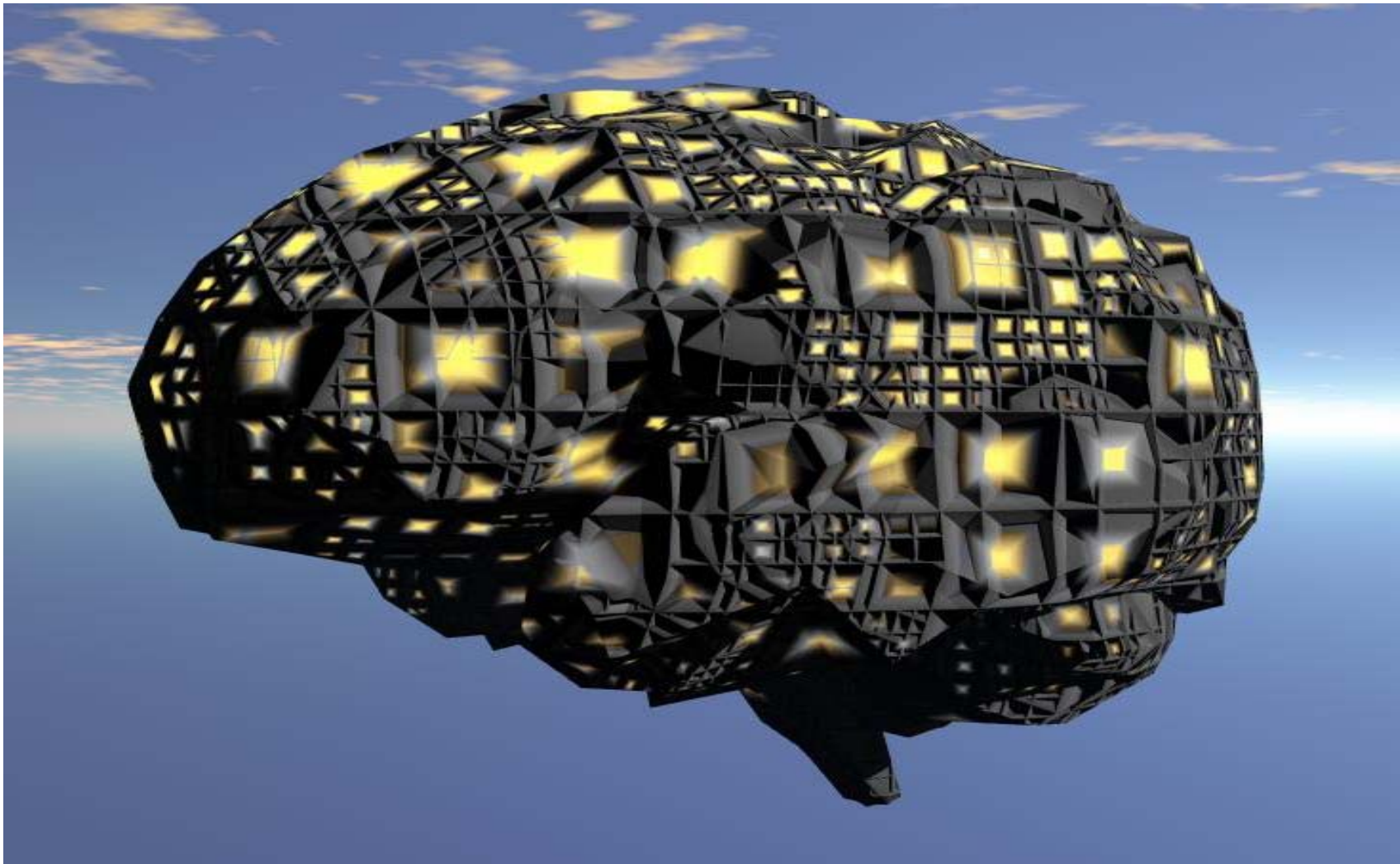
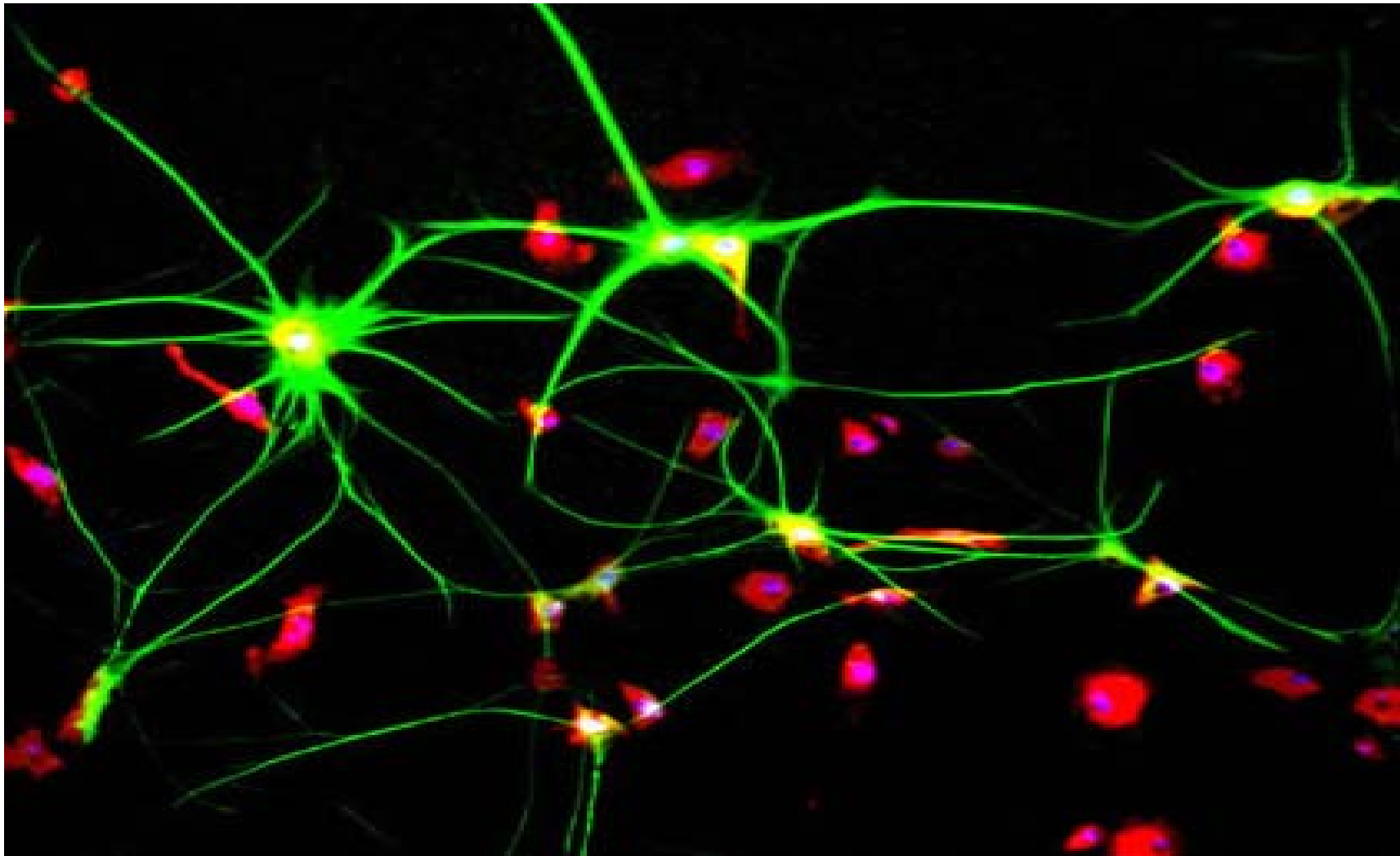

Photo: Credo Chronicler



Computational Nervous System





Data Centers

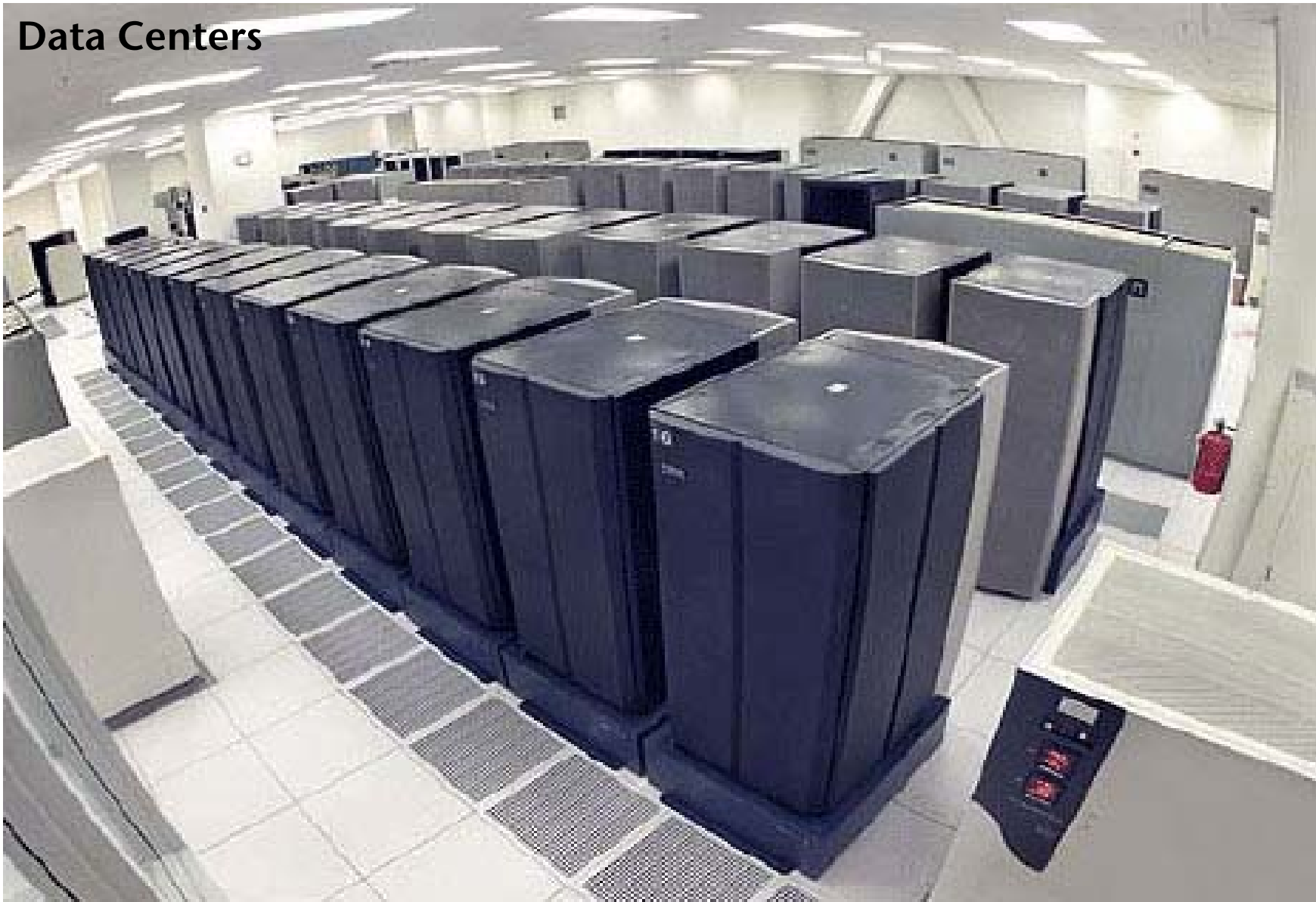

Autonomic Technologies



Autonomic Control Loop



The Common Factor

- ❑ Feedback loop between an autonomic manager and a collection of managed elements

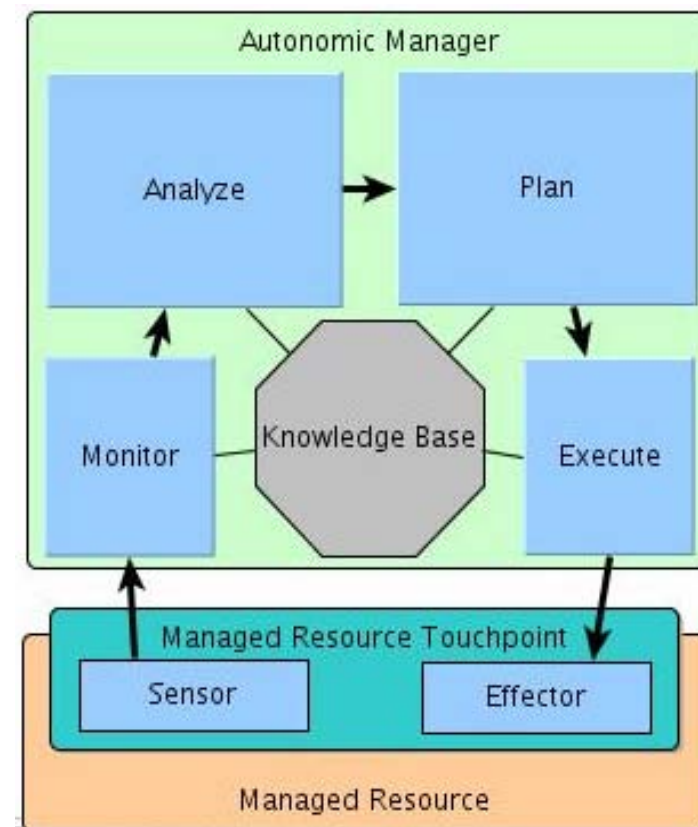
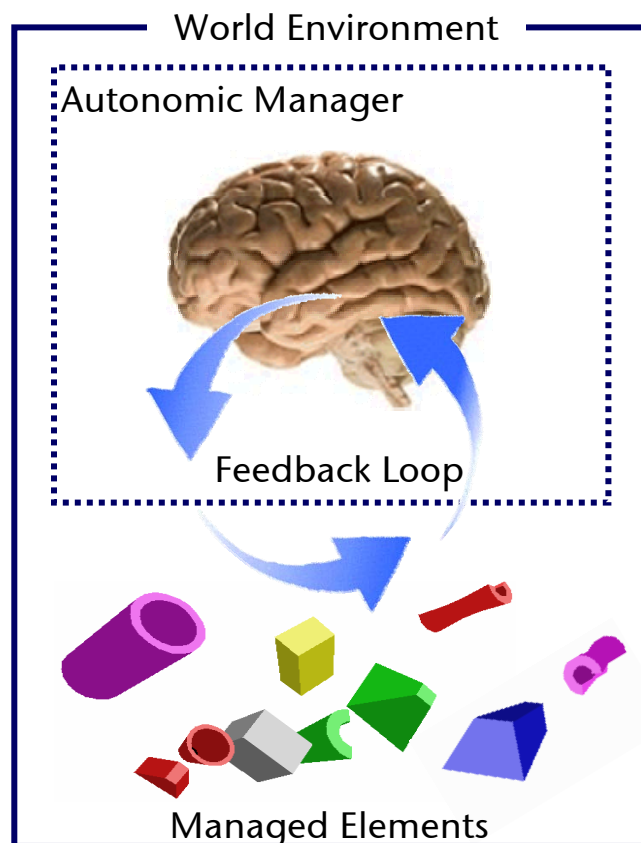

Autonomous and Autonomic



A² Computing (A²C)

- A natural harmony of concepts
 - Two related aspects of the same biological model
- An Autonomic Manager *must* be autonomous
 - Otherwise *self*-* cannot be created

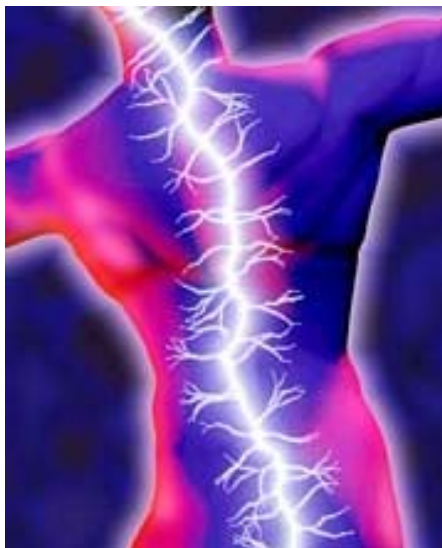

Proposition

- A²C principles are central to much of future computing for business applications
- Goal-oriented software engineering, based on BDI concepts, is an ideal solution technology for A²C



Complexity and Change is a Significant Concern

- ❑ The increasing complexity and dynamics of business, technical, and human cooperation networks demand *computer systems and software that exhibit:*
 - The capacity for adapting to business growth and change
 - Cooperating autonomous, self-organizing software components, instead of stovepipe centralized approaches
 - Continuous real-time *plan-and-execute* rather than static *plan-then-execute*
- ❑ Major push for technology to be unseen
 - *seamlessly embedded into business operations*
 - Coordination between systems is essential
 - Ontology based semantics are becoming important





From Laboratory to Commercial Reality

- ❑ Telecommunications
- ❑ Logistics
- ❑ Automotive
- ❑ Aerospace
- ❑ Financial Systems
- ❑ Military
- ❑ Manufacturing Plant Control and Automation
- ❑ Power Management and Distribution
- ❑ IT Systems and Services
- ❑ Grid Computing

And the list goes on...

Whitestein Technologies AG



A world leader in the provision of innovative products, solutions, and services based on autonomous software agent technologies, autonomic computing, and autonomic communications

*Transportation
Logistics*

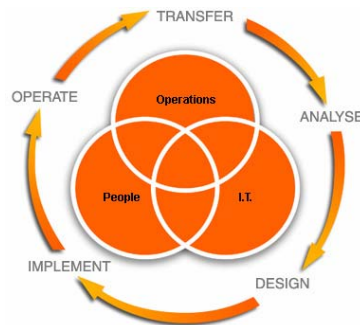

BPM

*Embedded
Control*



*Seamless
Mobility*



*Traffic
Management*



*Financial
Systems*



Key Facts

- ❑ Privately owned
- ❑ 7 years old
- ❑ 70 People
- ❑ 3 European Locations – Switzerland, Germany, Slovakia
- ❑ 3 Major Sectors – Telecommunications, Logistics/Control, BPM
- ❑ Sponsored book series: Whitestein Series in Software Agent Technologies and Autonomic Computing

 Whitestein Series
in Software Agent Technologies
and Autonomic Computing

Radovan Cervenka
Ivan Trencansky

AML
The Agent Modeling
Language

A Comprehensive Approach to
Modeling Multi-Agent Systems

Birkhäuser



Business Approach

- To identify and relieve real business *pain points*
 - Industry-specific solutions
 - Value proposition *first*, specific technological solution *afterward*

Key Technical Approach

- Goal-Oriented Autonomous Software Agent Technology
 - Visual GO Model creation and execution
 - Goals are *accomplished* or *maintained* with autonomous behaviors
 - Autonomic feedback control loops used to control operation
- ⇒ ***Dynamic, real-time resource planning and optimization***

Goal-Oriented Software Engineering



Towards Implicit Programming with Goals

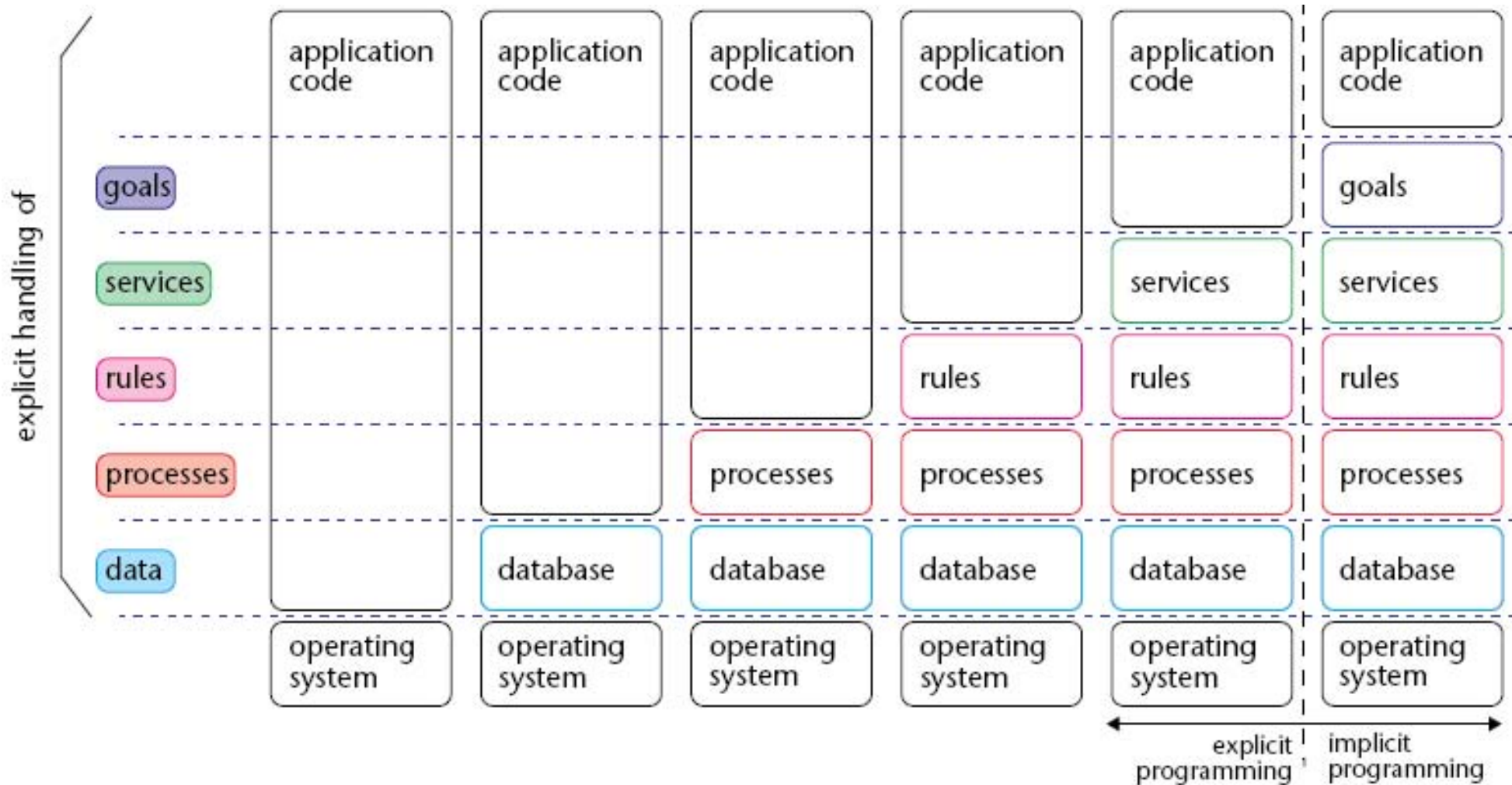

Goal-Oriented Software Engineering



The BDI Goal-Oriented Behaviour Engine

- ❑ A declarative programming methodology
- ❑ *Beliefs* – the current world state
- ❑ *Desires* – the desired world state (i.e., *goals*)
- ❑ *Intentions* – adopted desires
- ❑ *Plans* – the means to achieve intentions
- ❑ *Tasks* – the steps in a plan

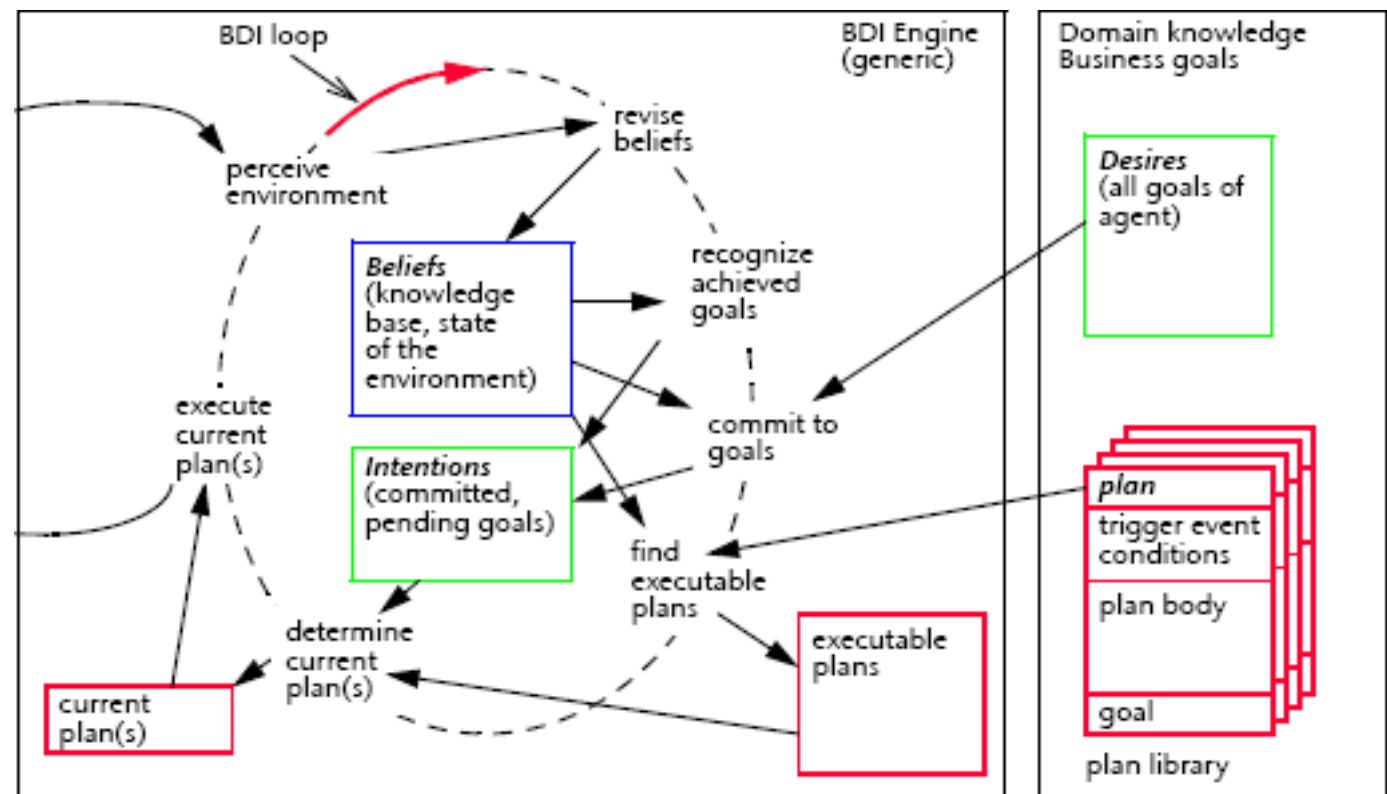

Goal-Oriented Software Engineering



A Goal is a desired state of the world

- ❑ *A utility function*
- ❑ Achievable by one or more plans
- ❑ Plans match goals with constraints
- ❑ Plan bodies consist of task actions

Goals can be

- ❑ Executed concurrently
- ❑ Hierarchically subsumed
- ❑ Either (for example):
 - Achievement goals
 - Maintenance goals

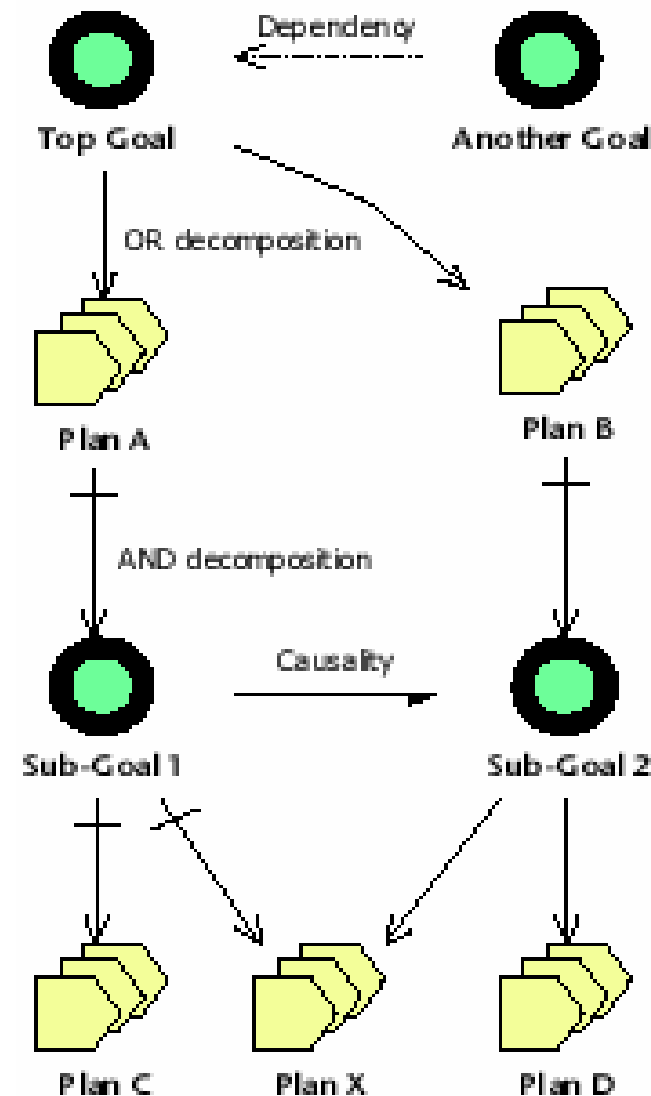



Autonomous

- The ability to independently perform some processing toward achieving or maintaining one or more goal
 - *is the very definition of an autonomous system*

Autonomic

- The ability to self-regulate a goal/plan hierarchy to make automatic adjustments in real-time in accordance with changing environment and requirements
 - *is the very definition of an autonomic system*

A²C

- Goal-oriented software engineering is thus an ideal tool for meeting the needs of contemporary business systems

Whitestein's Software Agent Platform



The Living Systems Technology Suite (LS/TS)

- ❑ An industry-grade, Java-based foundation for the professional development and operations of products and solutions based on software agent technology and autonomic computing
- ❑ AML Agent Modeling Language
- ❑ ADEM engineering methodology
- ❑ Eclipse tools
- ❑ J2SE and J2EE Runtimes
- ❑ Robust and scalable
- ❑ Standards compliant

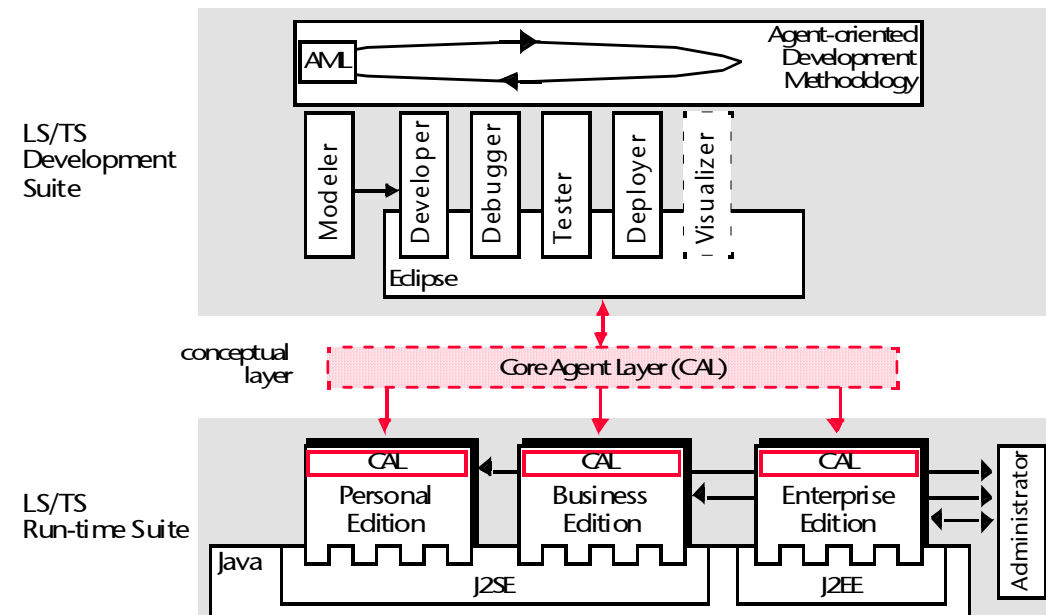



The Agent Modeling Language (AML)

- A UML Profile for specifying, modeling and documenting systems that incorporate concepts drawn from AS theory
- Autonomous systems entities
- Behavior abstraction and decomposition
- Observations and effecting interactions
- Communicative interactions
- Autonomic Control
- Mental and Social aspects
- Ontologies
- Deployment and Migration

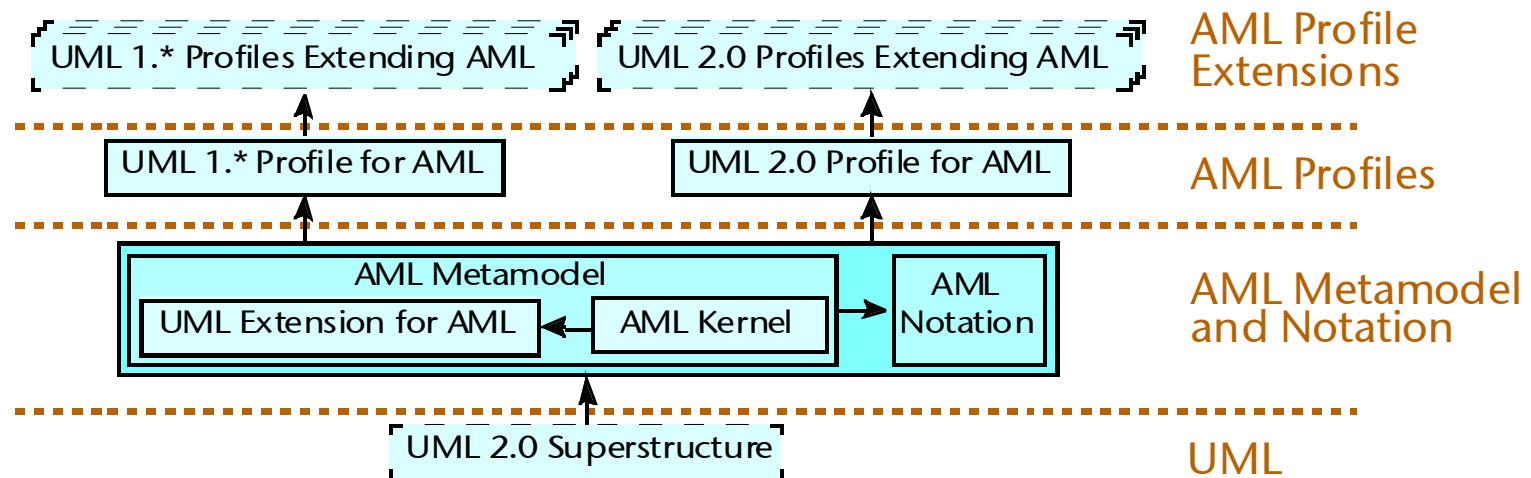



Semantic Data Engineering

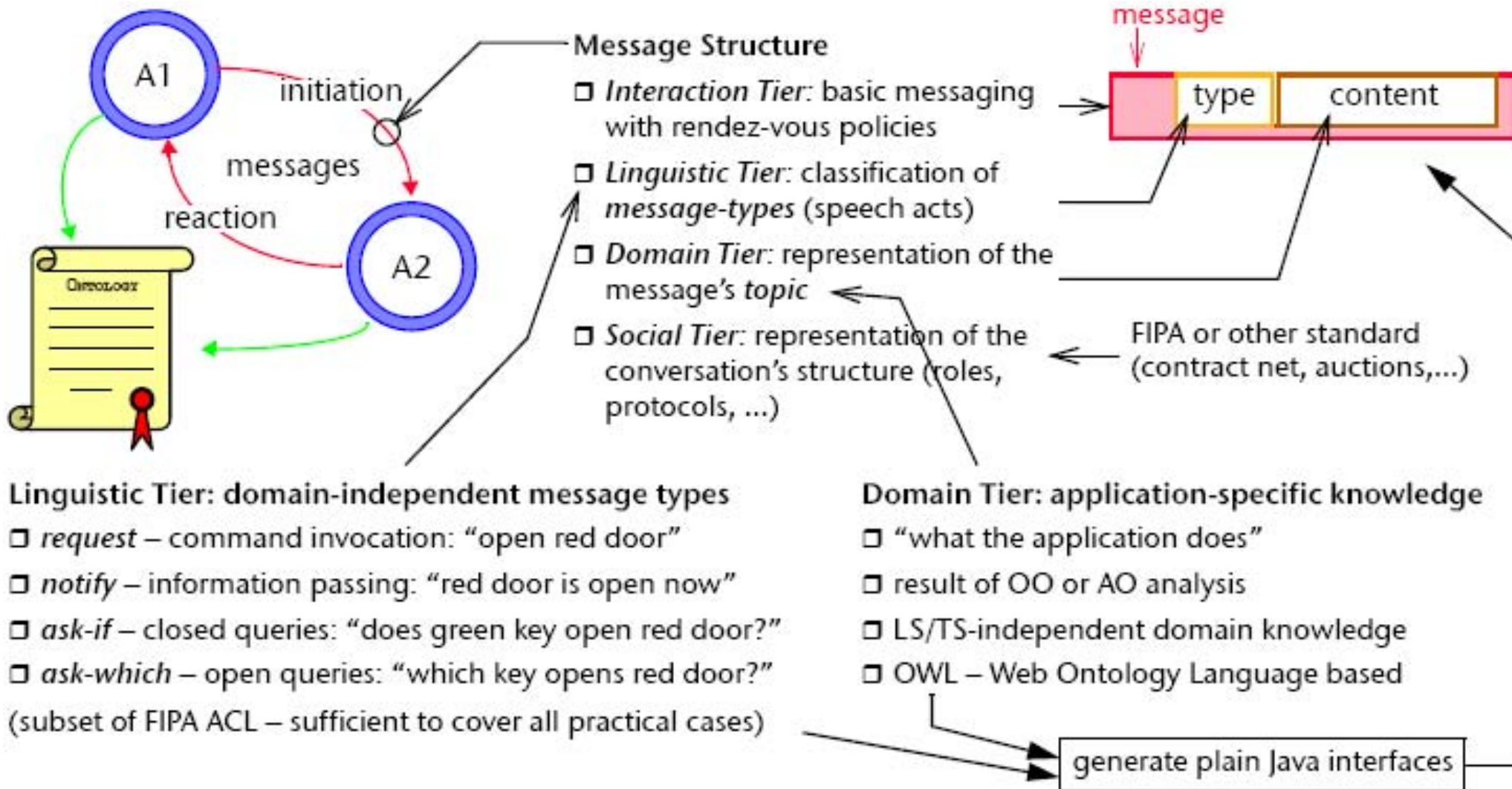

Governance via Policies



Use of Policies

- ❑ Provide an upper layer of governance
- ❑ Separation of *strategy* from *tactical* concerns
- ❑ An engine is required for processing policy expressions

Ponder² engine and PonderTalk

- ❑ An emerging technology from Imperial College London
 - Provides a *common architectural pattern* for policy application
 - Smalltalk-like policy expression language (PonderTalk)
 - Allows dynamic association of an event with a policy
 - Supports deontic obligations and authorizations





- *Business Process Management* -

Autonomic Business Process Management

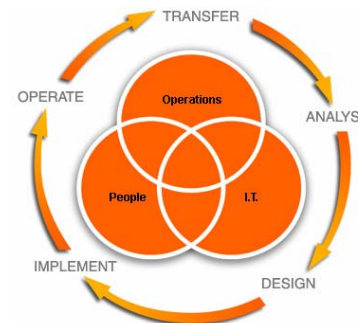

Business Process Management (BPM)



LS Autonomic Business Process Management (LS/ABPM)

- ❑ Convention is toward inflexible, hard-coded processes
- ❑ ABPM approach allows agile, context-sensitive *process navigation* by using Goals and Plans
 - Goals identify targets for a process, or portion of a process
 - Plans are selected dynamically to achieve goals
- ❑ Each business process has its own *autonomic controller*
 - Each autonomic controller executes its own goal-oriented business process model instance
- ❑ Processes modeled with executable GO-BPMN

Business Process Navigation (BPN)



Process Navigation with Goal-Oriented Process Models (GO-BPMN)

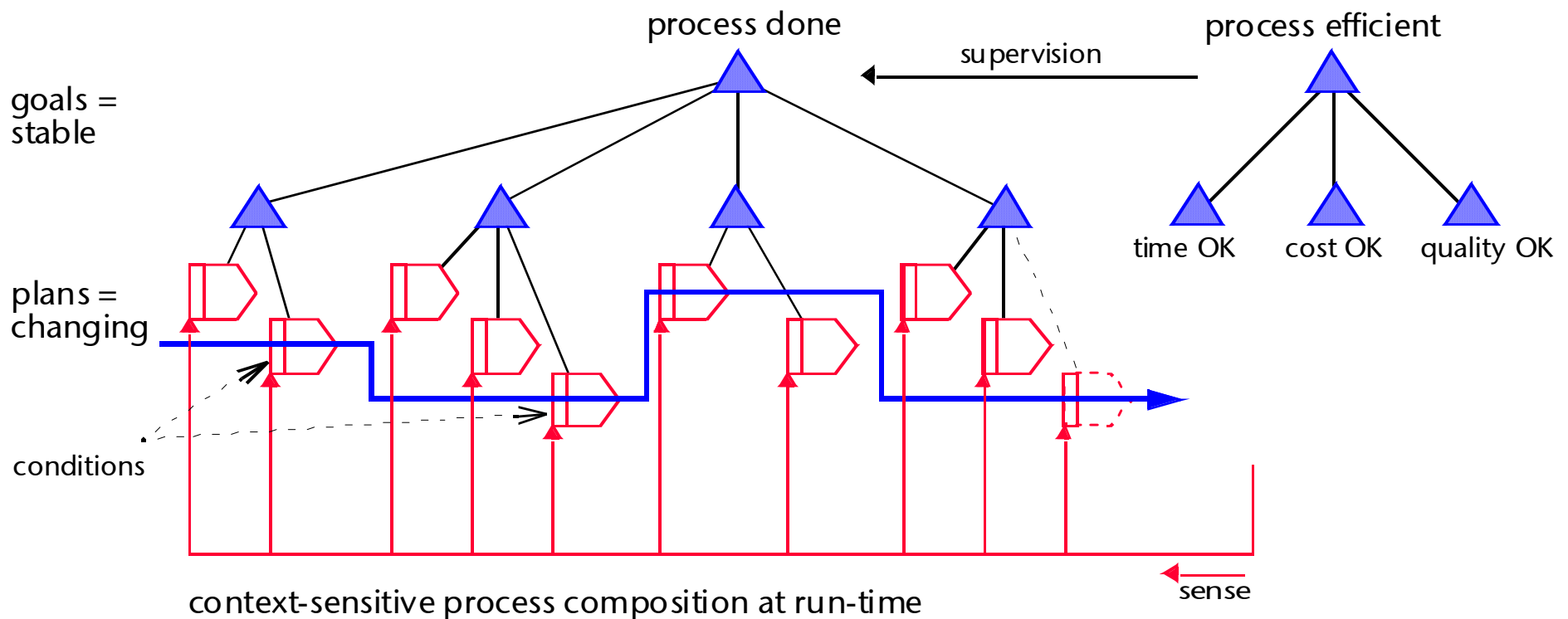

(business) goals = stable over time
actions (plans) to achieve goals change and are easily modified

Business Process Navigation (BPN)



Process Modeling

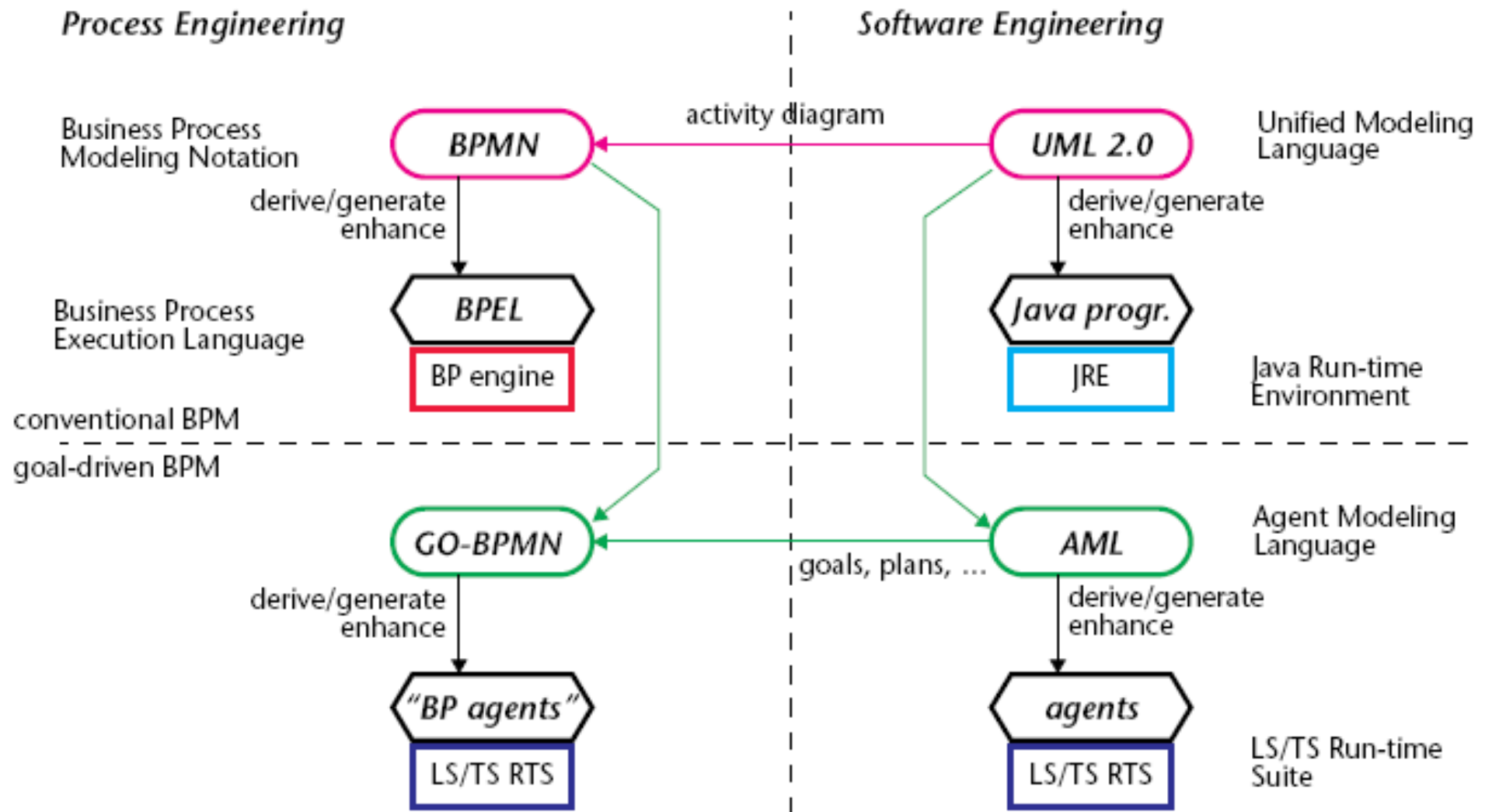

Autonomic Business Process Management



DaimlerChrysler





Agile Change Management

- ❑ Incorporating business processes such as
 - product change management (product life cycle management)
 - product design and engineering
 - procurement (purchasing), supplier integration/management

- ❑ Mastering business process uncertainty and change
 - High levels of run-time uncertainty
 - High variability needed to cope with different business situations

The “Pain Point”

- ❑ Design- and Run-time uncertainty and variability cannot be properly supported with current system



LS Autonomic Business Process Management (LS/ABPM)

- ❑ Process definitions can be changed at any time, even for already running processes

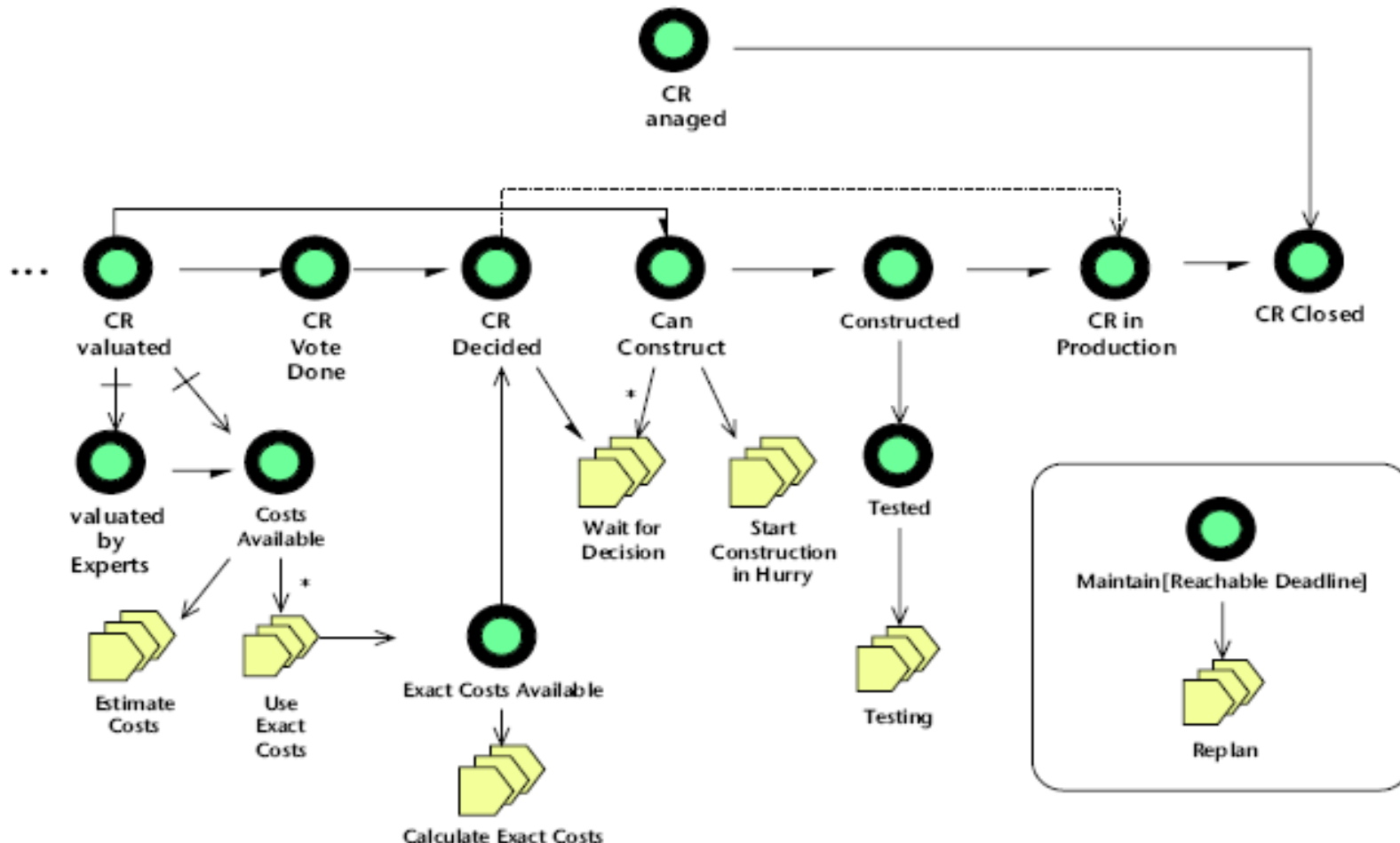



LS Autonomic Business Process Management (LS/ABPM)

□ Autonomous Factors

- Goal-Orientation separates the declarative statements defining required process behaviour from the various ways to achieve that behaviour
- Implicit, rather than conventional explicit, programming maps well to *business objectives*
- Mastering change and uncertainty through autonomous controllers provides process agility

□ Autonomic Factors

- Building self-management within the business process logic
- Restructuring of goals and plans dynamically at runtime
- ⇒ Adaptation of process behavior to prevailing run-time conditions and business contexts



- Telecommunications -

Seamless
Mobility



Data and
Service
Aggregation

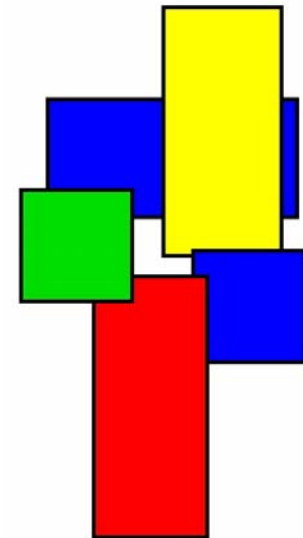

Service Access &
Provisioning
Management



Seamless Mobility



LS Connection Agent (LS/CA)

❑ Policy Based Connection Manager

- Connection establishment and management for multiple networking technologies: HSDPA-GPRS, WLAN, Ethernet; on request: POTS, ADSL
- Seamless session handover between technologies (Mobile IP)
- Rules-based decisions on handover (always best connected)
- Autonomic self-configuration

❑ For laptops, PDAs, etc.

❑ Hybrid network support for disruptive environments





LS Connection Agent (LS/CA)

❑ Autonomous Factors

- Each deployment is managed by an embedded autonomous software agent

❑ Autonomic Factors

- **SC:** Policy controlled configuration according to changing network conditions, location, session requirements, etc.
- **SO:** Adjust connection type according to need, roaming, service-specific, cost, reduced bandwidth, etc.
- **SH:** Detect faults (e.g., network cards, drivers) and automatically repair or transition to alternative connection
- **SP:** Detect unauthorized alterations to obfuscated operator policies and securely obtain a refresh



LS Autonomic Service Access Management (LS/ASAM)

- ❑ Automatic negotiation-based QoS/QoE sensitive service provisioning in access networks

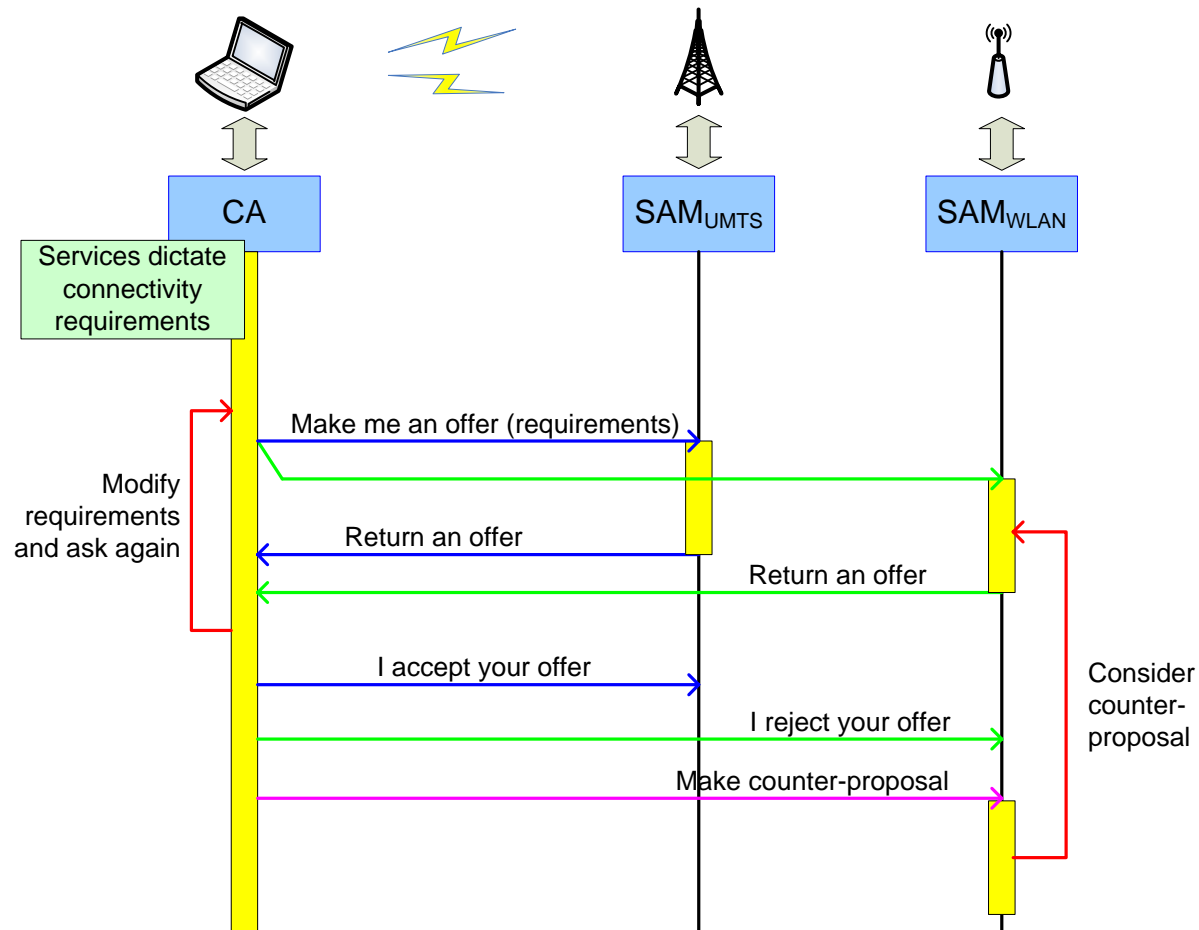



LS Autonomic Service Access Management (LS/ASAM)

❑ Autonomous Factors

- Each client and network device has an embedded autonomous software agent
- Can make decisions based on sensed network conditions, user preferences and provider policies

❑ Autonomic Factors

- **SC:** Service provisioning adapted according to available connection types and QoS offers
- **SO:** Optimize connection according to variable QoS and QoE
- **SH:** Automatic session transfer to alternative connections



LS Autonomic Service Composition and Orchestration

- ❑ Building dynamic *value composites* with Goal-Oriented logic
- ❑ Use Semantic descriptions to express the ontological relationships present in domain-specific data and services
 - Allows more effective discovery of, and reasoning about, according to semantic descriptions of business goals
- ❑ Adaptation of compositions according to the data/service availability and changing availability, requirements, or policies
- ❑ Consideration of multiple providers
 - Classic content and providers
 - Emerging WebV2.0 notion of *Prosumers*

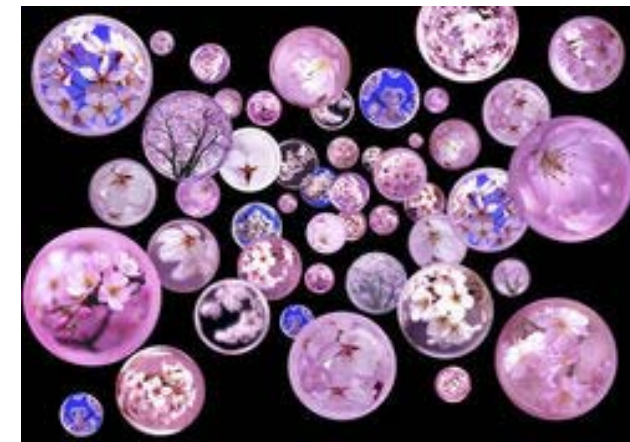



LS Autonomic Service Composition and Orchestration

❑ Autonomous Factors

- Each composition is controlled and guided by a goal-oriented autonomous software agent

❑ Autonomic Factors

- **SC:** Compositions are dynamically (re-)configured according to availabilities, changing requirements and policies
- **SO:** Compositions can be automatically optimized in terms of available sources
- **SH:** Compositions can be automatically repaired through discovery of replacement sources, or functionally degraded if not possible



- *Logistics* -

Adaptive Transportation Networks



Adaptive Supply Chain Networks



Adaptive Production Networks

Real-Time Optimized Planning



Inter-related via the Supply Chain

- ❑ Mesh of relationships between an Enterprise, its suppliers and customers

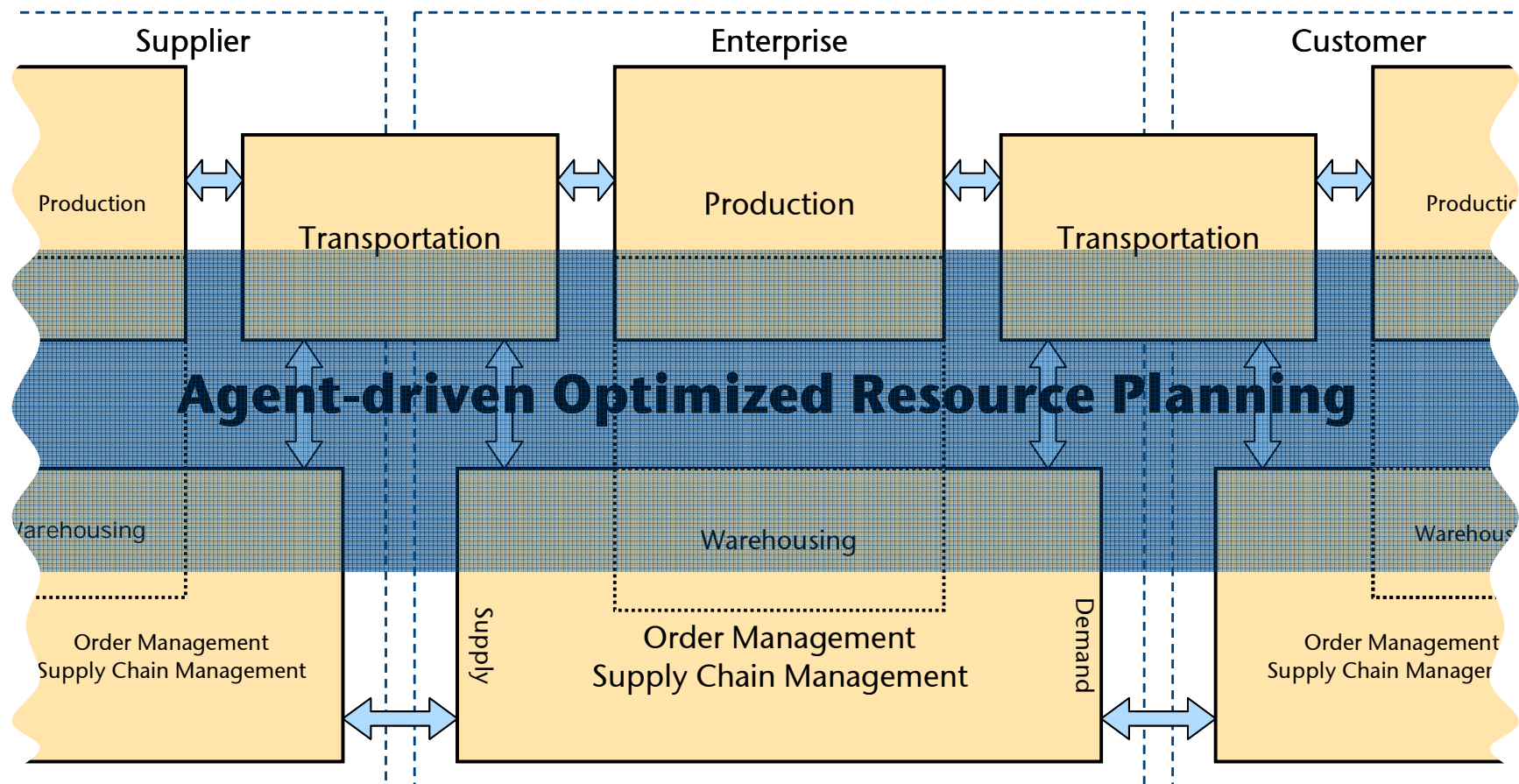

Adaptive Transportation Networks



Customer: DHL



Adaptive Transportation Networks



Continuous, real-time cost-based route optimization

□ *DHL's Pain point*: Dynamic TSP problem

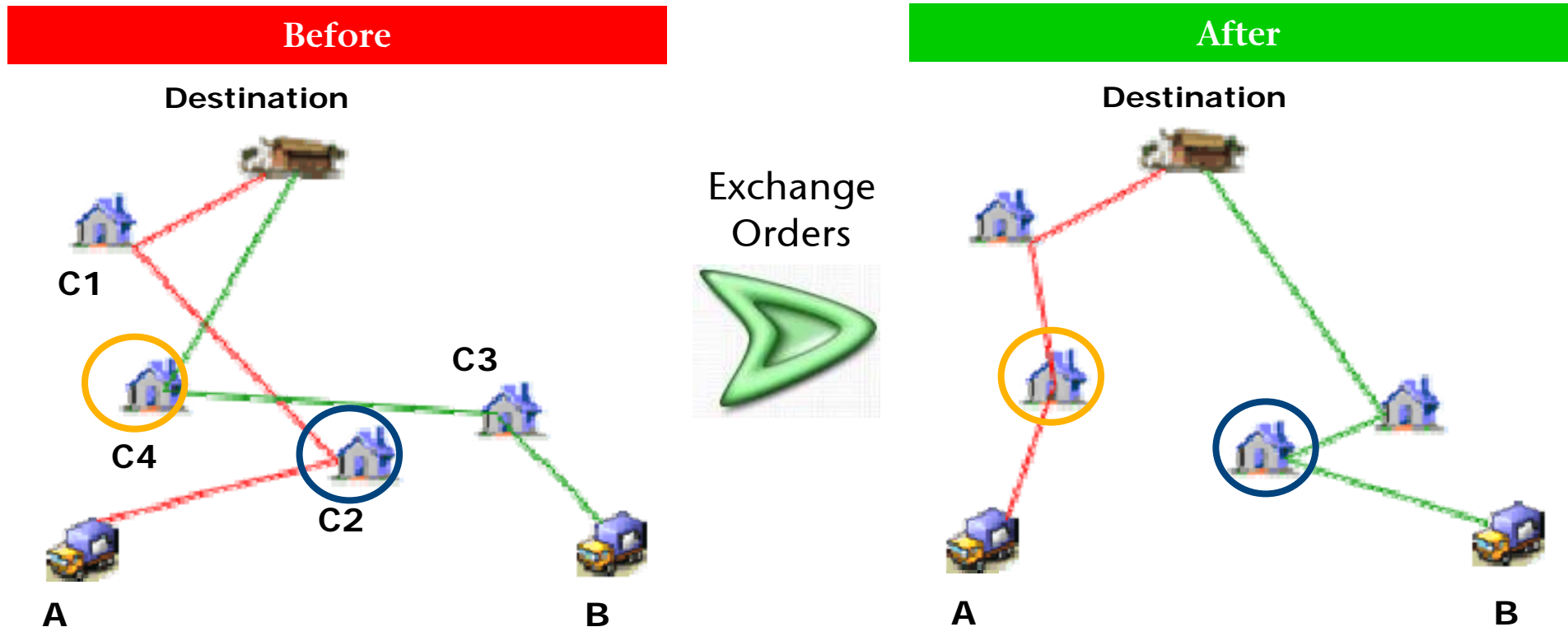

Adaptive Transportation Networks



Europe-wide network of distributed route planners

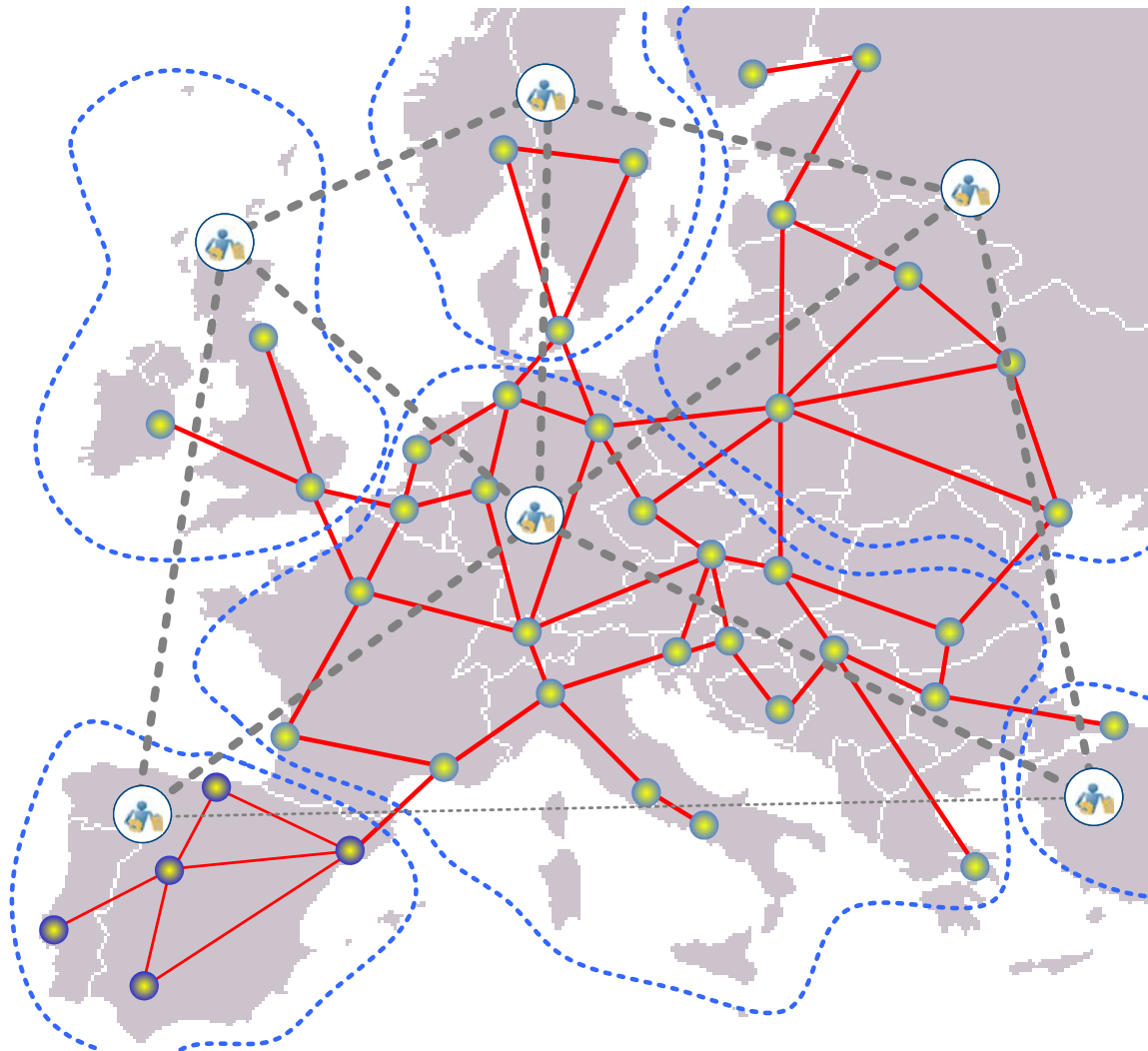

- Optimized allocation of 40,000 orders
- to 15,000 trucks
- by 300 dispatchers
- **Per day**
- and with each order changing at least once

Adaptive Transportation Networks



Continuous, real-time cost-based route optimization

- ❑ Distributed coordination
- ❑ Multiple Pick up and Delivery Problem with Time Windows (mPDPTW)

- Continuously produce feasible schedules in real-time

- ❑ Order exchange via combinatorial goal-directed auctions
- ❑ Real-time data feeds

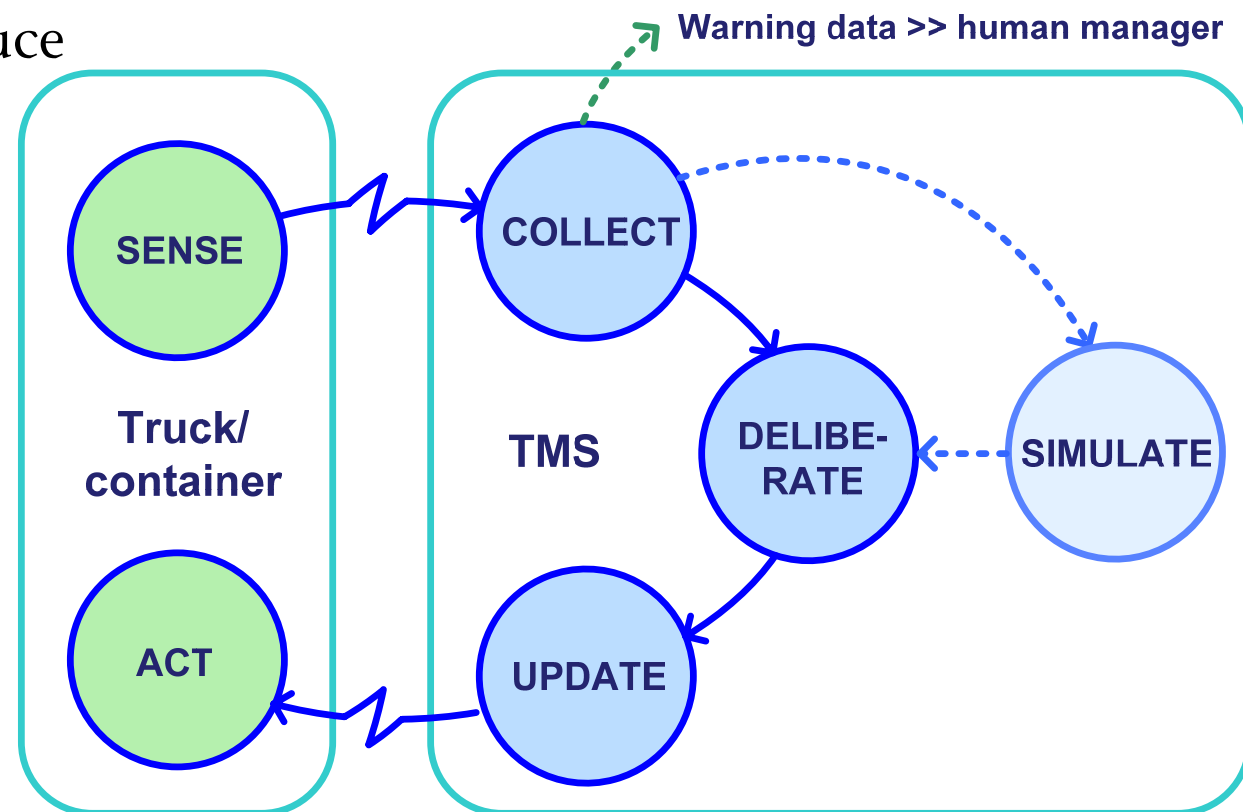



LS Adaptive Transportation Networks (LS/ATN)

□ Autonomous Factors

- Optimization problem space is automatically partitioned, distributed across a population of goal-directed autonomous agents and solved concurrently
- Collaboration allows sub-solutions to be consolidated

□ Autonomic Factors

- **SC:** Automatic adjustment of deployment according to geographics
- **SO:** Real-time data-feeds from vehicles assist route-plan optimization
- **SH:** Concurrent simulations *validate* route plans with feedback to tune the optimizer



LS Adaptive Production Networks (LS/APN)

- ❑ Optimization of production machinery scheduling
- ❑ Replacement of conventional static planning tools with real-time dynamic scheduling
 - Managing incoming orders vs. available production capacity
- ❑ Ability to identify and resolve bottlenecks continuously and preemptively
 - Reduce set-up and waiting times, and inventory levels
 - Increase throughput and performance
- ❑ Automatic generation of solution alternatives
 - Real-time, tactical and strategic planned through forward simulation planning

Adaptive Production Networks



Market-based control

Machine 1



Machine 2



Material 1



Machine 3



Operator 1



Machine 4



- ❑ Orders are represented as agents
- ❑ Machines are represented as agents
- ❑ Agents negotiate directly with one another with different goals
- ❑ Orders: Minimize turn-around time
- ❑ Machines: Maximize extent of utilization & throughput

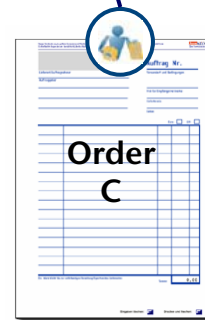
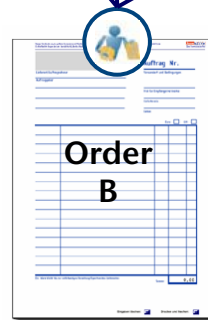
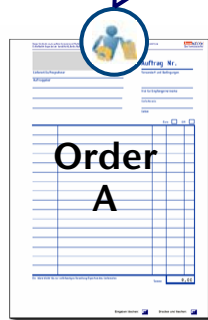

Adaptive Production Networks



Identify alternative processes

- Continuous situation simulation allows immediate decisions from identified alternative scenarios

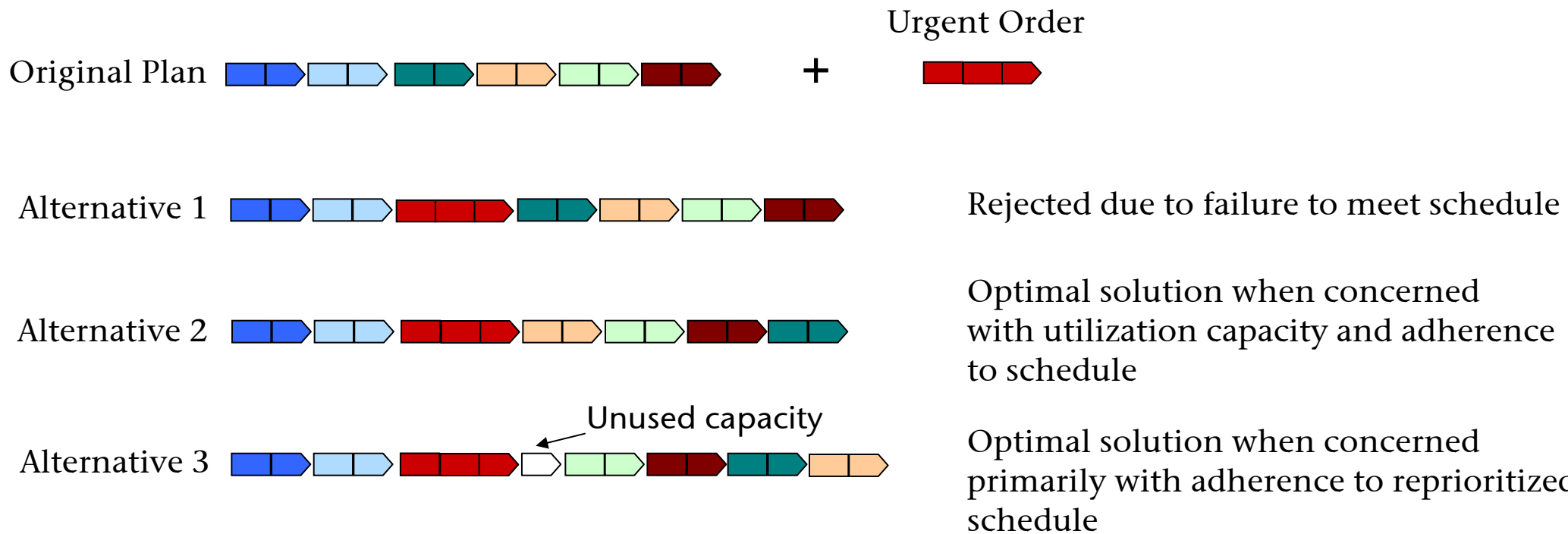



LS Adaptive Production Networks (LS/APN)

□ Autonomous Factors

- Each order and each machine is represented by an autonomous agent.
- Inter-agent collaboration used to (re-)negotiate schedule solutions in accordance with changing orders, usage constraints, production scheduling and operator availability

□ Autonomic Factors

- **SC:** Automatic adjustment of deployment as production site grows (or shrinks)
- **SO:** Continuous optimization of schedules
- **SH:** If machinery breaks down the production schedule will automatically re-plan to compensate



- Control -

Autonomic Machine Control



Autonomic Traffic Control

Embedded Machine Control



LS Autonomic Machine Control (LS/AMC)

- ❑ Embedded autonomous control elements
- ❑ Local control and distributed coordination

Production Example

- ❑ Modular soldering machine
- ❑ Modules are autonomous and coordinate dynamically

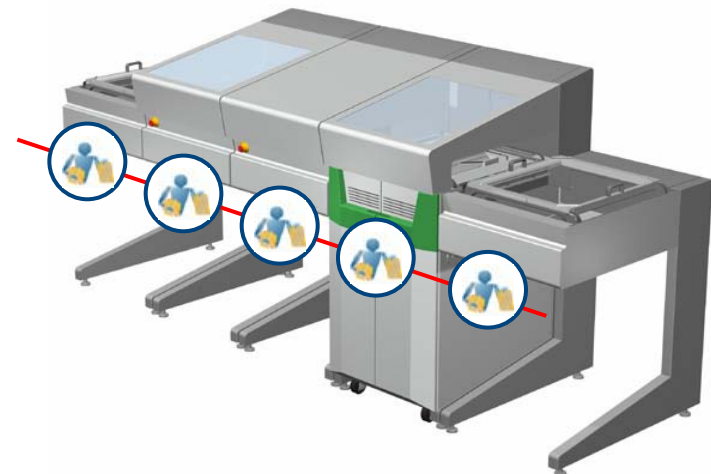
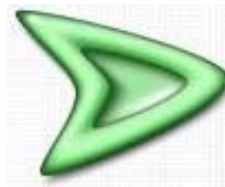



LS Autonomic Machine Control (LS/AMC)

□ Autonomous Factors

- Each module in a deployment is managed by an embedded autonomous software agent
- Each agent uses goals to perform it's local operations in coordination with others

□ Autonomic Factors

- **SC:** Each agent adapts the operation of the module it is responsible for
- **SO:** Optimization is achieved through overall distributed coordination to maximize performance
- **SH:** Not available due to limitations imposed by scarce resources

Distributed Machine Control



LS Autonomic Traffic Control (LS/ATC)

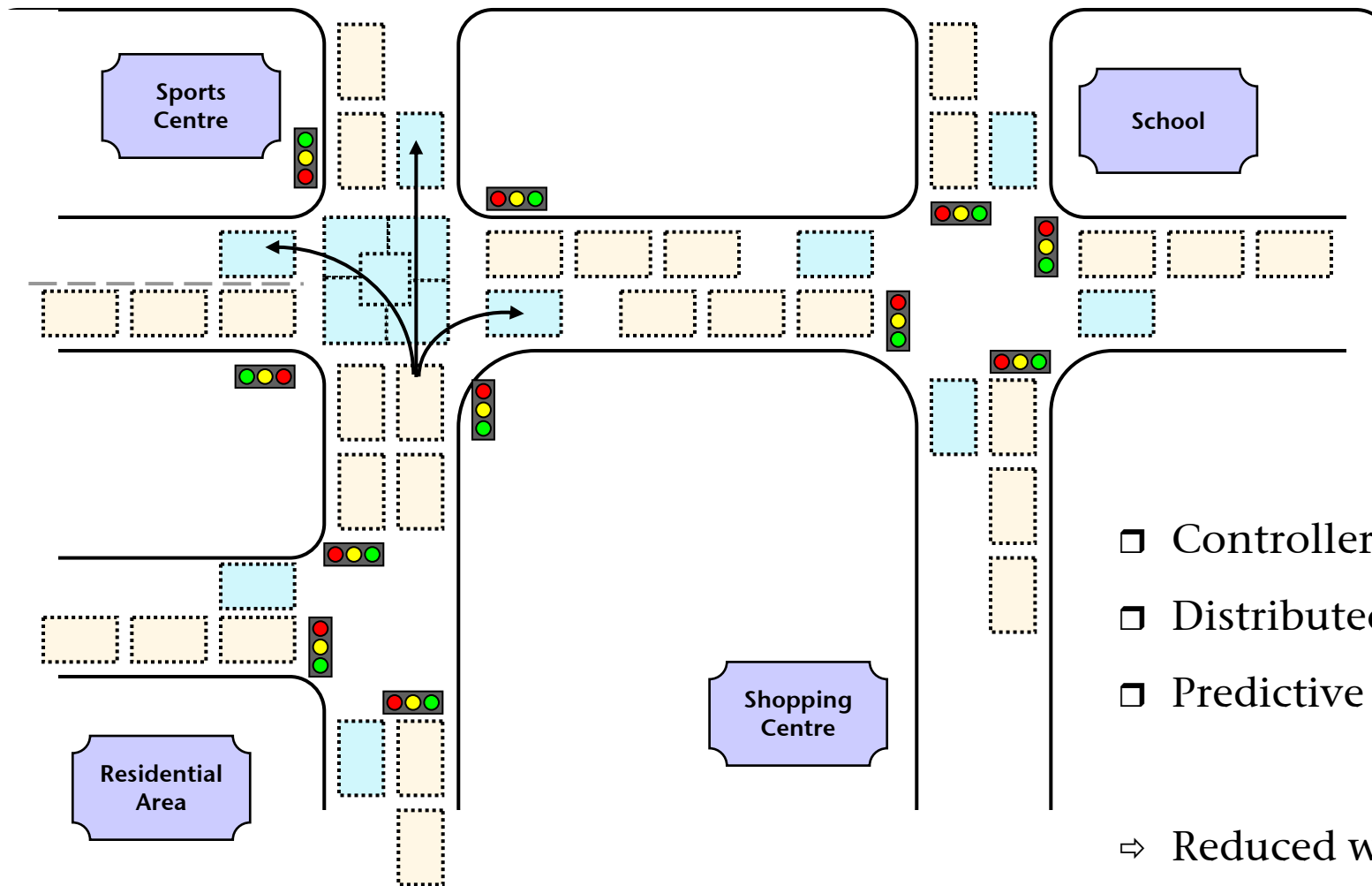

- ❑ Controller per intersection
- ❑ Distributed coordination
- ❑ Predictive estimations

- ⇒ Reduced waiting times
- ⇒ Reduced pollution



LS Autonomic Machine Control (LS/AMC)

□ Autonomous Factors

- Each intersection installation has an embedded autonomous controller
- Acts only in coordination with other controllers
- Performs local queuing analysis (imaging) and shares findings

□ Autonomic Factors

- **SC:** System is configured dynamically via cooperation
- **SO:** Continuous optimization to find best sequence solution
- **SH:** Failure of one intersection can result in others adapting to compensate for (and/or control) changes in traffic flow
- **SP:** Constraints ensure sequences are safe

Closing Remarks



A²C systems are spreading rapidly

(and have been for some time)

- ❑ Autonomous and Autonomic are two aspects of the same ideological and technological stance

- ❑ They are intuitively understandable concepts for business, in part because of their biological foundation

- ❑ They are increasingly finding their way into many aspects of software engineering and multiple business sectors

Gartner Hype Curve

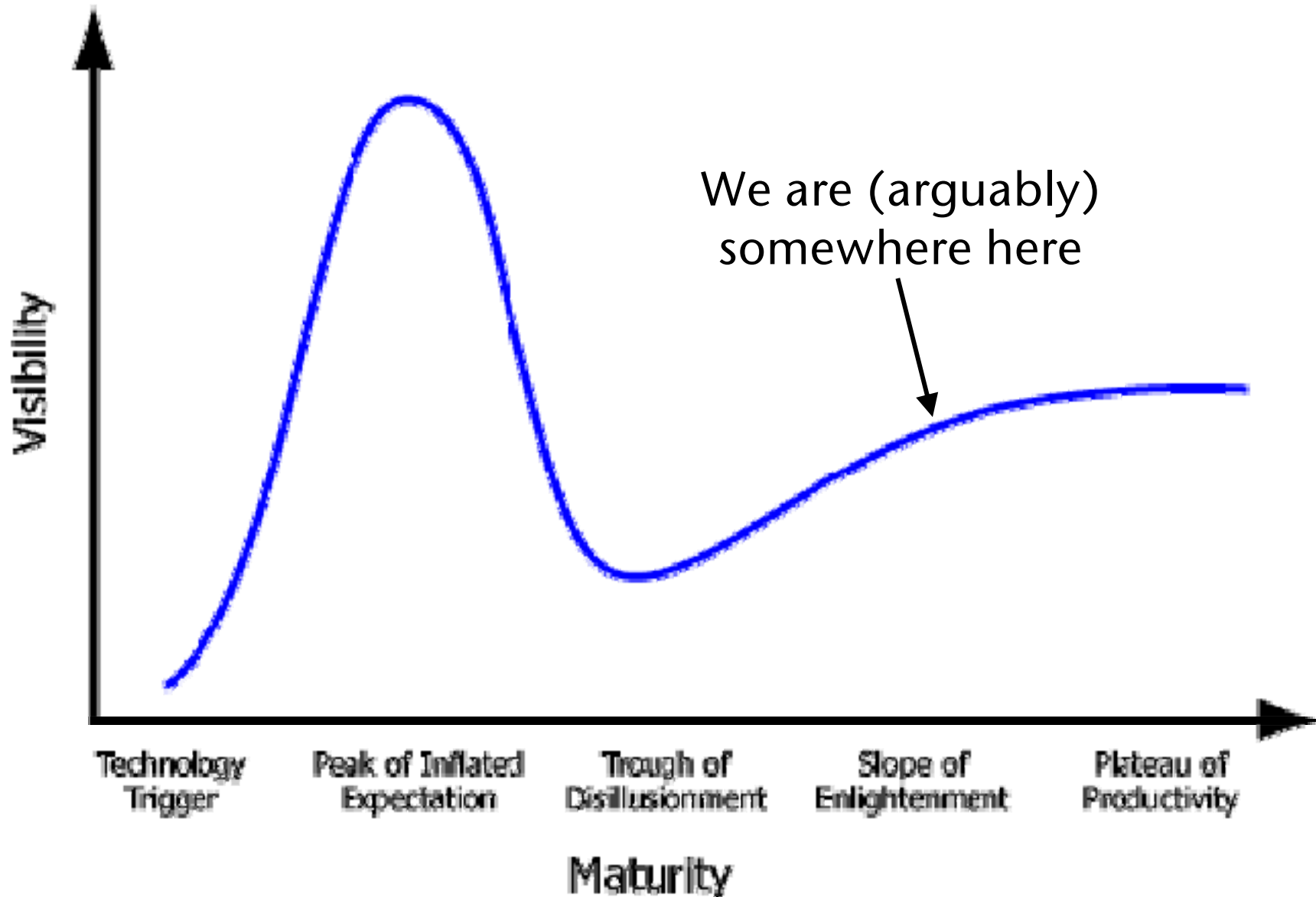

Thank you.



WHITESTEIN
Technologies

Realizing Tangible Business Value from the
Fusion of Autonomous and Autonomic
Technologies

Dominic Greenwood
Head of Innovation